

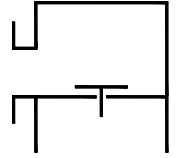

Type sheet

Vacuum relief valve

KITO® VS/ScS-...



Application

Not explosion-proof valve to prevent dangerous vacuums in tank installations. For installation on tank roofs, if desired by the customer, in connection with a pressure valve.

In case of use in explosive atmospheres of gas/vapour-air mixtures ignition hazards need to be considered. Plastic material tends to electrostatic charging. The use should be completed respectively decided by a risk analysis considering country-specific rules and regulations.

Dimensions (mm) and settings (mbar)

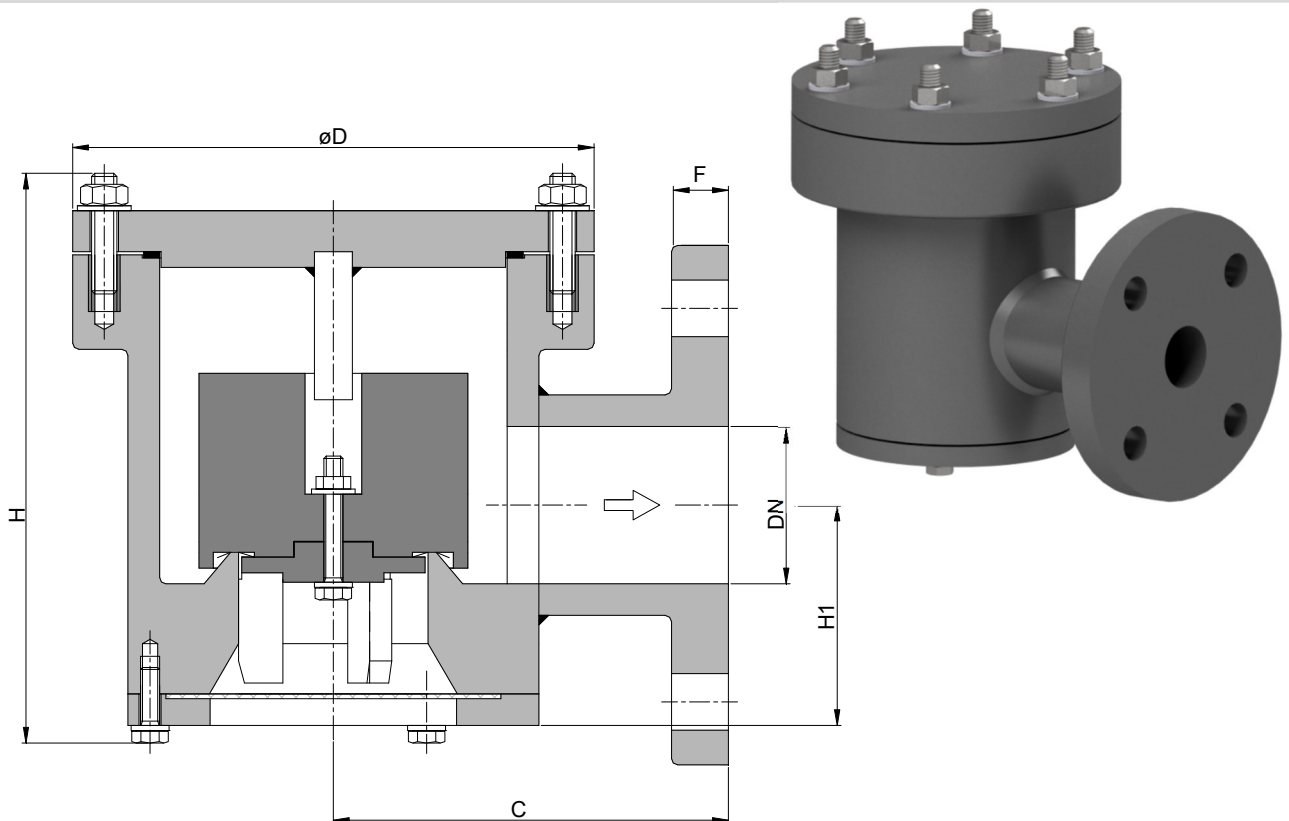

DIN	DN	ASME	C	D	H	H1	F	setting		kg
								min.	max.	
25 PN 40	1"	120	130	167	50	16	3.1	30	1.5	
50 PN 16	2"	125	165	186	70	18	2.4		2.0	
80 PN 16	3"	150	210	234	96	20	2.4		3.5	
100 PN 16	4"	175	245	284	115	24	2.3		5.0	
150 PN 16	6"	250	320	350	158	26	2.3		9.5	
200 PN 10	8"	275	394	435	210	28	2.7		17.0	

Indicated weights are understood without weight load and refer to the standard design

Example for order

KITO® VS/SCS-50

(design with flange connection DN 50 PN 16)

Without EC certificate and CE-marking

Type sheet

Vacuum relief valve

KITO® VS/ScS-...

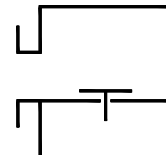

Design

	standard	optionally
housing / cover	polyethylene (PE)	polypropylene (PP)
gasket	Gylon	
valve pallet / guidance	polyethylene (PE)	polypropylene (PP)
sealing foil	FEP	
load weight	polyethylene (PE) <i>(at higher settings PE/stainless steel)</i>	polypropylene (PP) <i>(at higher settings PP/stainless steel)</i>
bolts / nuts (inside)	PEEK	Hastelloy C4
bolts / nuts (outside)	A2	
protective screen	polyamide 6	
connection	flange EN 1092-1 type A	flange ASME B16.5 Class 150 RF, weld end

Performance curves

Flow capacity V based on air of a density $\rho = 1.29 \text{ kg/m}^3$ at $T = 273 \text{ K}$ and atmospheric pressure $p = 1.013 \text{ mbar}$. For other gases the flow can be approximately calculated by

$$\dot{V}_{40\%} = \dot{V}_b \cdot \sqrt{\frac{\rho_b}{1.29}} \quad \text{or} \quad \dot{V}_b = \dot{V}_{40\%} \cdot \sqrt{\frac{1.29}{\rho_b}}$$

The indicated flow rates will be reached by an accumulation of 40% above valve's setting (see DIN 4119).
If the allowable overpressure is less 40%, please consult der factory for the corrected volume flow.

