

TERMOSTAT TCON-CSD/20

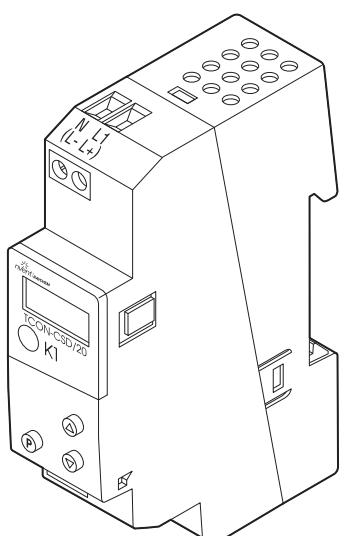

The nVent RAYCHEM TCON-CSD/20 is a compact digital thermostat for simple ON/OFF temperature control. The temperature is measured through a temperature sensor and shown on a LCD display. The actual status of the output relay is signaled via a LED.

The instrument is commissioned and operated via three soft key push buttons on the unit's front panel.

Through its compact design and robust construction the TCON-CSD/20 allows for simple and space-saving installation.

Specific features:

- Time-delayed controller activation after initial power up (can be used to avoid peak demands on power during start-up)
- Parameter level can be protected by means of a secret code
- Adjustable switching differential.
- Input sensors are permanently monitored for cable short or breakage.

GENERAL

Application	Usable for all applications requiring tight temperature control for either line sensing or ambient sensing control
Area of use	DIN rail mounting in panels or enclosures installed in non-hazardous area. Sensing temperature in hazardous area Zone 1 is possible when used in conjunction with nVent RAYCHEM MONI-PT100-EXE or nVent RAYCHEM MONI-PT100-EXE-SENSOR (separately available)
Temperature control range	-200°C to +500°C (accuracy 0.1%)
Ambient operating temperature	0°C to +55°C
Storage temperature	-40°C to +70°C
Climatic conditions	≤75% relative humidity, no condensation
LED indicator	The LED at the front of the unit lights up when the output relay is energized.

ENCLOSURE

Protection	IP 20 to EN 60529
Material	Polycarbonate
Installation	On 35 x 7.5 mm DIN rail
Installation position	Any position allowed
Flammability class	UL 94 V0

APPROVALS

EAC TC RU C-BE.БЛ08.B.01634
Made in GE

DIMENSIONS (IN MM)

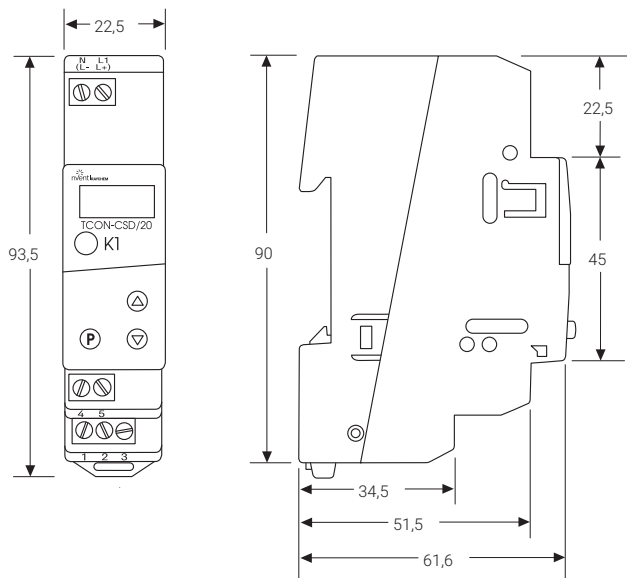

WIRING DIAGRAM

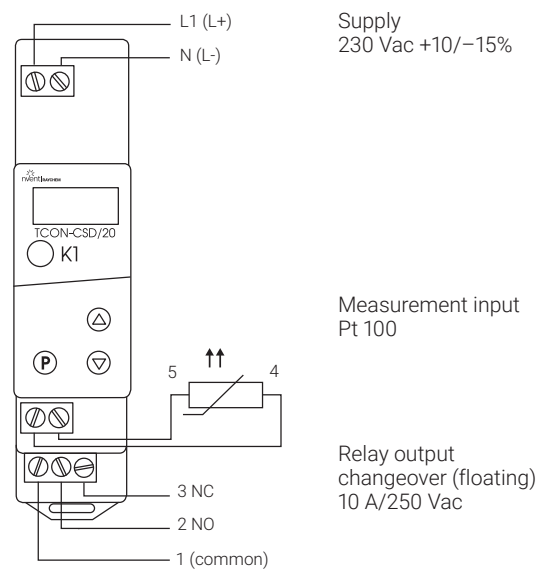

ELECTRICAL DATA

Power supply & own power consumption	230 Vac +10/-15%, 48 – 63 Hz < 1 VA
Connection terminals	Screw terminals for wires with a maximum cross-section of 2.5 mm ²
Relay output	10 A rated changeover contact (SPDT)
Contact lifetime	A minimum lifetime of 150 K operations at 10 A/250 Vac 50 Hz resistive load.

TEMPERATURE SENSOR

Pt100, Pt1000 or KTY2X-6 all connected in 2-wire circuit Sensor “open” and sensor “short” will be automatically detected and will cause the output to switch to the customer programmed default either permanently ON or OFF When using 2-wire temperature sensors there will be an error on the temperature readout of approximately 1°C per 0.39 Ohm lead resistance added. TCON-CSD/20 units are equipped with an option to compensate for the cable resistance added in order to improve the accuracy. Refer to the installation instructions for more details.

When the sensor cable is laid in cable ducts or in the vicinity of high voltage carrying cables the sensor extension cable should be shielded. The shield of the extension cable should be grounded at the controller end only.

Switching point accuracy	±2% of range span
Switching differential	Adjustable from 0.25% to 5% (factory set at minimum value)
Zero point correction	Enables matching of the switching point and probe accuracy (offset)

ELECTROMAGNETIC COMPATIBILITY

To EN 61 326. Emission approved to Class B, immunity to industrial requirements

ELECTRICAL SAFETY

To EN 61 010, Part 1, over voltage category III, pollution degree 2

DATA BACKUP

EEPROM (unit does not loose configuration settings after power outage)

ORDERING DETAILS

Order reference & weight 1244-001133 (0.11 kg)